

JKTech Specialist Consulting

Flotation Circuit Flowsheet Design



Improve confidence in Flotation Flowsheet Design, using current models and simulation.

Four steps to flotation circuit design

The JKTech flotation circuit flowsheet design methodology, incorporating the JKSimFloat software, is a sequence of the following steps:

1. Measure
2. Analyse
3. Simulate
4. Optimise and Design

1. Measure

There are two levels of data collection:

- Concept or pre-feasibility
- Feasibility

In the concept or pre-feasibility stage, a series of JK Floatability Index tests can be conducted to estimate the floatability parameters for use in the circuit design. Additional machine parameters (cell size, bubble surface area flux, froth recovery) are also obtained from JKTech's extensive database of industrial flotation cells.

In order to develop an understanding of a specific flotation circuit in a feasibility stage of a design, JKTech flotation specialists can conduct metallurgical surveys, laboratory flotation tests and flotation cell characterisation measurements on a pilot plant trial of the new ore. These measurements have been developed and validated over the past fifteen years through research conducted at many flotation operations.



2. Analyse

Analysis of the flotation circuit measurements, including gas dispersion, mass balancing, pulp and froth zone characteristics and floatability component analysis are performed to develop the flotation model that is used for process simulation and optimisation.

The model can be developed on either an unsized or a size-by-assay basis. A size-by-assay model increases the users confidence in simulation results.

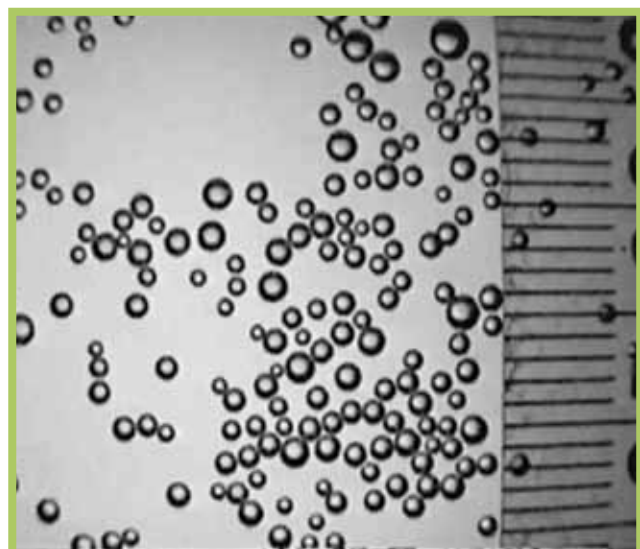

3. Simulate with

The flotation simulation software package, JKSimFloat, was developed to assist in understanding and optimising the flotation process. In this stage, the JKSimFloat simulator is calibrated so as to predict the operating results of the plant during the survey and measurement campaign.

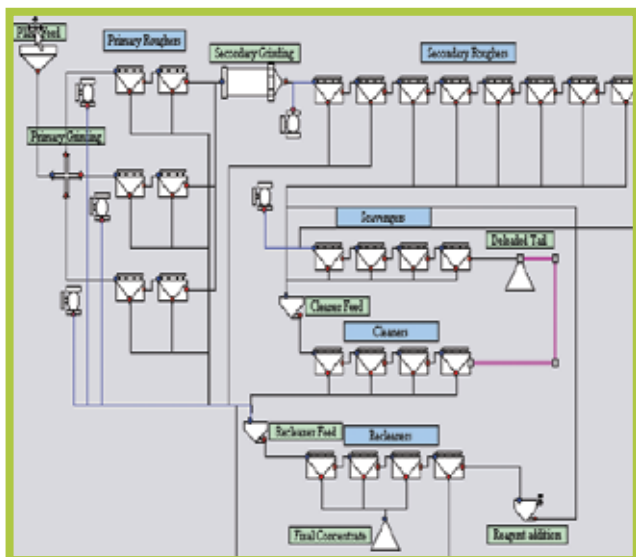

4. Optimise and Design

Once the JKSimFloat model has been calibrated, the simulator can be used to predict the effect of circuit and operating variable changes on flotation circuit performance.

This allows changes in circuit performance to be evaluated and hence provide the optimal flowsheet design. Often this optimal design is then re-tested in a pilot plant to ensure key plant performance criteria are met.



JKTech Services

- Consulting (comminution, flotation, mineralogy, mining & geometallurgy)
- Process Mineralogy and In-House Instrument Analysis
- Specialist Software (JKSimMet, JKSimFloat, JKMultiBal, JKSimBlast)
- Specialist Equipment (ore breakage characterisation, flotation characterisation)
- Metallurgical Laboratory Services
- SMI Knowledge Transfer

Contact

David Collins
Manager Flotation

Telephone: +61 7 3365 5970
Facsimile: +61 7 3365 5900
Email: d.collins@jktech.com.au

JKTech's range of technologies is supported by the ongoing research activities of the Sustainable Minerals Institute at The University of Queensland.

